



CODE	DESCRIPTION	PRICE/DELIVERY
<b>TCF024-002600</b>	Verticle manual FLYWHEEL slicer for cured meats, blade diameter 350 mm, standard colours: RED, BLACK, CREAM or customizable on request, dim. mm 710x870x800h.	<b>€ 3.595,13</b> <i>VAT excluded</i> <b>Shipping to be calculated</b> <b>Delivery from 8 to 15 days</b>

**PROFESSIONAL DESCRIPTION**

**MANUAL FLYWHEEL SLICER, blade diameter 350 mm, made of aluminum alloy and steel parts, with fire enamelling,**

- **built in aluminum and steel parts** with a **fired painting**, it is a **real jewel with a design** with attention to the smallest detail,
- **cutting thickness from 0 to 2.5 mm** - 9 positions,
- **cutting capacity: mm 270x240h** ,
- built-in sharpener,
- the flywheel is manual and **can therefore work even in places without electricity;**
- robust, durable and reliable, a product for true connoisseurs,
- equipped with **ring protection around the blade in compliance with EEC standards,**
- **totally customizable** in terms of color and finishes,
- **standard colours: red, black, cream** (to be specified when ordering).

**Accessories/Options :**

- rose flowered shuttlecock
- pedestal



**NB : BASIC VERSION WITH SMOOTH FLYWHEEL** . The flowered shuttlecock is an optional, see price in the accessories.

**CE MARK**  
**MADE IN ITALY**

**TECHNICAL CARD**

<b>net weight (Kg)</b>	81
<b>gross weight (Kg)</b>	90
<b>breadth (mm)</b>	710
<b>depth (mm)</b>	870
<b>height (mm)</b>	800

**TECHNICAL CARD**

CODE/PICTURES	DESCRIPTION	PRICE/DELIVERY
<p><b>TCF024-005007</b></p> 	<p><b>TECHNOCHEF - Rose Flowered Flywheel, Mod.FLOWERED ROSE 350/370</b> Rose flowered flywheel for flywheel / manual slicers Mod. 350/370</p>	<p><b>€ 290,42</b> <i>VAT excluded</i> <b>Shipping to be calculated</b> <b>Delivery</b> from 4 to 9 days</p>
<p><b>TCF024-005002</b></p> 	<p><b>TECHNOCHEF - Pedestal, Mod.PD 350/370</b> Pedestal for flywheel / manual slicers Mod. 350/370.</p>	<p><b>€ 873,60</b> <i>VAT excluded</i> <b>Shipping to be calculated</b> <b>Delivery</b> from 8 to 15 days</p>





TECHNOCHEF.IT



TECHNOCHEF.IT



TECHNOCHEF.IT

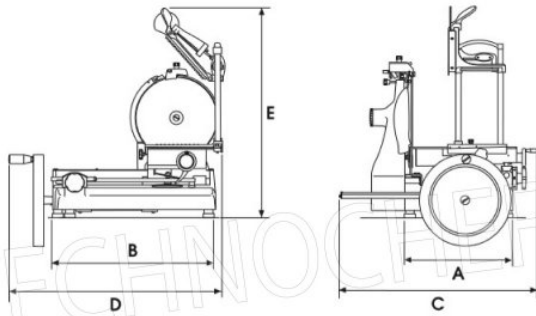

**F 350 VOLANO**

**F 370 VOLANO**

<b>A</b> mm	400	400
<b>B</b> mm	650	650
<b>C</b> mm	710	710
<b>D</b> mm	870	870
<b>E</b> mm	800	800
kg	81	81

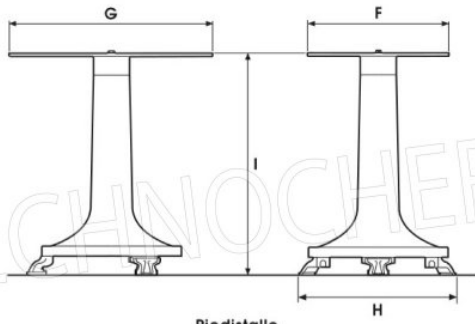

**Pedistallo**

<b>F</b> mm	450
<b>G</b> mm	700
<b>H</b> mm	640
<b>I</b> mm	<b>795</b>
kg	<b>53</b>