



TECNOSERVICE'21 srl

by Tinti Sergio
Via Carlo Pisacane, 134
61032 Fano (PU) Italy
P.IVA IT0200411413

Tel. +39 0721 805911
FAX +39 0721 809794
e-mail: staff@technochef.it
www.technochef.it
www.technochef.eu

Services and Technologies for professional catering since 1973



CODE	DESCRIPTION	PRICE/DELIVERY
CD-A90/1B	Pastry Freezer-Freezer Cabinet, for 20 TRAYS of 600x800 mm or 40 TRAYS of 600x400 mm, 1 Door, Professional, Temp.-10°/-22°C, Ventilated, ECOLOGICAL in Class D, Gas R290, V.230/1 , Kw.1,00, Weight 180 Kg, dim.mm.810x1015x2085h	

PROFESSIONAL DESCRIPTION

FREEZER-FREEZER CABINET for PASTRY, 1 Door, 900 lt, Temp. -10°/-22°C -- Suitable for containing 20 600x800 mm pastry trays or 40 600x400 mm pastry trays -- ECOLOGICAL in Class D ,

- **Internal/external in AISI 304 stainless steel ;**
- external back, bottom and internal technical compartment in galvanized/laminated steel;
- Rounded internal corners for easy cleaning;
- **Racks and guides in AISI 304 stainless steel ;**
- AISI 304 stainless steel handle, 2 mm thick;
- 1 self-closing door with 105° stop, hinges on the right;
- Triple chamber door seal, magnetic, easily replaceable;
- **Ventilated refrigeration** with indirect air flow;
- **Hot gas/electric defrost** (remote);
- **Automatic evaporation** of condensate;
- Monocoque structure with **75 mm insulation** - CFC/HCFC free;
- Anti-corrosion treated evaporator;
- Electronic control, flush panel display;
- Made with FSS - Fast Service System - technology for easy and fast service;
- Prepared for connection to a remote supervision system;
- **led illumination ;**
- **Lock with key ;**
- Adjustable **feet in AISI 304 stainless steel** h 100-150 mm.

TECHNICAL DATA :

- Gross capacity 872 litres
- **Temperature range -10°/-22°C**
- Plug-In refrigeration unit
- **Energy efficiency class D**
- Energy efficiency index: 64
- Annual consumption: 2916 kW/h per annum
- 24h consumption: 7,989 kW/h/24h
- Climate class: 5
- **Ecological refrigerant gas R290**
- Defrost: With hot gas
- Solenoid valve supplied as standard
- Power consumption 1000 W
- Current absorbed 4.6 A
- Cooling capacity 692 W* (Evap. -30°C Cond. +55°C)

Supplied :

- **20 pairs of guides for 60x80 cm trays or grills** or 40 60x40 cm trays or grills
- LED lighting

**CE MARK
MADE IN ITALY**

TECHNICAL CARD

power supply	Monofase
Volts	V 230/1
frequency (Hz)	50
motor power capacity (Kw)	1,00
gross weight (Kg)	180
breadth (mm)	810
depth (mm)	1015
height (mm)	2085

Disegno tecnico

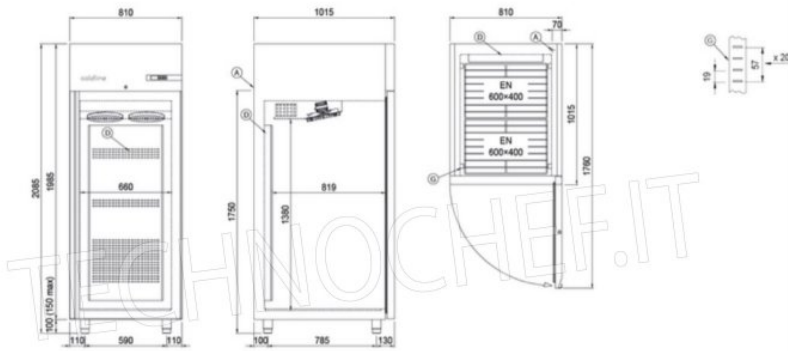

A: Uscita cavo alimentazione
G: Cremagliere

D: Diffusore flusso aria