



TECNOSERVICE'21 srl
by Tinti Sergio
Via Carlo Pisacane, 134
61032 Fano (PU) Italy
P.IVA IT0200411413

Tel. +39 0721 805911
FAX +39 0721 809794
e-mail: staff@technochef.it
www.technochef.it
www.technochef.eu

Services and Technologies for professional catering since 1973



PROFESSIONAL DESCRIPTION

WALL FRIGOR DISPLAY UNIT for FRUIT and VEGETABLES, VULCANO 80 line, 764 mm DEEP, 1330 mm LONG, available WITH and WITHOUT REFRIGERANT GROUP, in standard RAL colours, TECNODOM brand :

- PLUG-IN vertical refrigerated display, compact, suitable for displaying and preserving fresh and pre-packaged products;
 - **ecological , reliable , hygienic , suitable for all sales surfaces ;**
 - designed with particular attention aimed at **ease of installation** and **optimization of the cleaning system** , guaranteed by easy access to the internal parts;
 - the products on display are always kept at an **ideal temperature** , thanks to the refrigerated air flow and a well-sized refrigeration system;
 - VULCANO is a product with **low energy consumption** and **low environmental impact** : the tank is made without the use of CFCs;
 - **made of sheet metal painted in standard RAL colours ;**
 - compact but with a large exhibition surface: 2.10 m²;
 - suitable for small, medium and large distribution;
 - all phases, from design to production, have been taken care of in detail: **Made in Italy technology and design ;**
 - possibility of customization on request;
 - **ventilated refrigeration;**
 - **operating temperature +6°/+8°C ;**
 - climate class: 3 (ambient temperature +25°C, relative humidity 60%);
 - **thermoformed and insulated shoulders** (40 mm thick each), with **tempered glass side ;**
 - **electronic control panel ;**
 - **defrost at stop ;**
 - **upper neon lighting ;**
 - power absorbed lights n°xKw: 1x18;
 - **manual self-retracting night curtain ;**
 - **3 inclined shelves in non-toxic white post-painted sheet metal or in stainless steel** (for stainless steel version), equipped with price holder, without lighting, without product holding grids and an upper mirror;
- **AVAILABLE VERSIONS :**
1. **set up with finishing in the standard RAL colours** : blue, green, orange, yellow, red, black and white;
 2. **setup with stainless steel finish** (Optional);
 3. **version with built-in refrigeration unit** (equipped with a condensation water recovery and evaporation system, via stainless steel coil);
 4. **version with provision for remote refrigeration unit ;**
- R404A/R507 valve both in the version with and without refrigeration unit;
 - **available in 7 different RAL colors to specify when ordering** : **Blue** (RAL 5013), **Green** (RAL 6026), **Orange** (RAL 2008), **Yellow** (RAL 1018), **Red** (RAL 3020), **Black** (RAL 9005), **White** (RAL 9010).

Accessories/Options :

- Additional shelves
- Bathtub dividers
- Shelf dividers
- Product holding grids
- Shelf lighting
- Trolley with wheels
- Remote refrigeration units
- Packaging in wooden cage
- available on request in stainless steel

CE mark
Made in Italy

TECHNICAL CARD

power supply	Monofase
Volts	V 230/1
frequency (Hz)	50
gross weight (Kg)	210
breadth (mm)	1330
depth (mm)	764
height (mm)	2040

AVAILABLE MODELS

TD-VULCANO80FV-125SG

Wall Display Refrigerator, VULCANO 80 Line, 1330 mm LONG, without refrigeration unit
 WALL DISPLAY FRIGOR, TECNODOM brand, VULCANO 80 line, with 3 inclined shelves, upper neon LIGHTING, temperature +6°/+8°C, set up for REMOTE REFRIGERANT UNIT, V.230/1, Kw.0,084, Weight 210 Kg, dim.mm.1330x764x2040h

TD-VULCANO80FV-125CG

Wall Display Refrigerator, VULCANO 80 Line, 1330 mm LONG, with refrigeration unit
 WALL DISPLAY REFRIGERATOR, TECNODOM brand, VULCANO 80 line, with 3 inclined shelves, upper neon LIGHTING, temperature +6°/+8°C, complete with REFRIGERANT UNIT, V.230/1, Kw.1,595, Weight 210 Kg, dim.mm.1330x764x2040h

TECHNICAL CARD

CODE/PICTURES	DESCRIPTION	PRICE/DELIVERY
TD-DIVISRIPV80 	SHELF DIVIDER for VULCANO 80 PAINTED Gray plastic-coated divider for VULCANO 80 shelf, dim.mm.380x150h	
TD-GRIFEPROD125 	PLASTICIZED WHITE RETAINER GRILL White plasticised product retainer grid for painted VULCANO (H 80 mm)	
TD-DIVISVASV80 	TANK DIVIDING for VULCANO 80 PAINTED VULCANO 80 varnished plastic-coated gray divider for bathtub, dim.mm.380x150h	
TD-DIVISRIPV80G 	SHELF DIVIDER for VULCANO 80 INOX Gray plasticised partition for shelf VULCANO 80 in stainless steel, dim.mm.380x150h	
TD-GRIFEPROD125G 	GRAY LATCH-PRODUCED GRILL Gray plasticised product holding grid for VULCANO inox (H 80 mm)	
TD-DIVISVASV80G 	TANK DIVIDING for VULCANO 80 INOX VULCANO 80 stainless steel gray plasticised divider for bathtub, dim.mm.380x150h	

TD-GABBIAV80125



Wooden cage

Wooden cage for VULCANO80-125

TD-ILLRIPV125/140/150B



WHITE LIGHT FOR SHELF

White neon lighting for shelves

TD-RIPSUPV80125



EXTRA SHELF-PLATED SHELF

Additional shelf in white painted sheet, 1250 mm.

TD-RIPSUPV80125I



ADDITIONAL STAINLESS STEEL SHELF

Additional shelf in stainless steel, 1250 mm.

TD-ILLRIPV125/140/150R



ROSE LIGHTING for SHELF

'Natural' neon pink lighting for shelves

TD-UCE8/4



SINGLE-PHASE REMOTE REFRIGERANT UNITS

Remote sealed refrigerant unit Single-phase V.230 / 1, Yield W 1417, Refrigerant gas R404A / R507, positionable up to 15 meters (maximum distance including curves and ascents).



Versione in acciaio inox



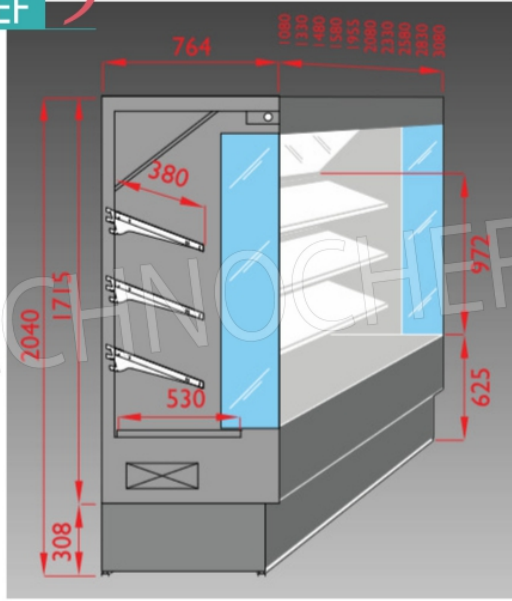

TECHNO CHEF.IT