



TECNOSERVICE'21 srl

by Tinti Sergio
Via Carlo Pisacane, 134
61032 Fano (PU) Italy
P.IVA IT0200411413

Tel. +39 0721 805911
FAX +39 0721 809794
e-mail: staff@technochef.it
www.technochef.it
www.technochef.eu

Services and Technologies for professional catering since 1973



PROFESSIONAL DESCRIPTION

ACTIVATED CARBON SUCTION and DEODORIZATION UNITS with POCKET PRE-FILTER and 2 SYNTHETIC FILTERS, COMPLETE RANGE in THREE-PHASE version, with max flow rate from 3,000 to 12,000 m³/cu/h:

- **air deodorization and filtration units** complete with **double suction centrifugal fan in version with belts and pulleys** ;
- EU3 type 85% gravimetric **air pre-filter** ;
- **pocket filter** type EU9 95% gravimetric;
- **cylinders with activated vegetable carbon** in small cylinders type 207/C;
- **aluminum profile frame** ;
- **double paneling in galvanized steel inside and stainless steel outside** ;
- double panel;
- 3-piece construction for Mods: CCA 175 (1150+600+650 mm), CCA 190 / 1120 (1200+600+800 mm).

Accessories/Options:

- spare carbon filter, diam.mm 160x400
- spare coal bag, weight 25 Kg.

NB : on request the control unit is available in the **2-speed version** with a 10% surcharge

CE mark
Made in Italy

AVAILABLE MODELS

TCF475-004100



Activated carbon deodorization units with pocket and synthetic pre-filter, THREE-PHASE V.400/3 DEODORIZATION UNIT with 9 CYLINDERS of activated vegetable carbon, pocket pre-filter and 2 synthetic filters, max flow rate 3000 m³/cubic/h, rpm 1750, V.400/3, Kw.1,5, Weight 155 Kg, dim .mm.2000x670x670h

€ 2.206,40

VAT excluded
Shipping to be calculated

Delivery from 8 to 15 days

TCF475-004200

Activated carbon deodorization units with pocket and synthetic pre-filter, THREE-PHASE V.400/3
 DEODORIZATION UNIT with 14 CYLINDERS of activated vegetable carbon, pocket pre-filter and 2 synthetic filters, max flow rate 4500 m3/cubic/h, rpm 1410, V.400/3, Kw.2,2, Weight 200 Kg, dim .mm.2000x980x750h

€ 2.986,14

VAT excluded
Shipping to be calculated

Delivery from 8 to 15 days**TCF475-004300**

Activated carbon deodorization units with pocket and synthetic pre-filter, THREE-PHASE V.400/3
 DEODORIZATION UNIT with 18 CYLINDERS of activated vegetable carbon, pocket pre-filter and 2 synthetic filters, max. .mm.2100x1280x800h

€ 3.709,12

VAT excluded
Shipping to be calculated

Delivery from 8 to 15 days**TCF475-004400**

Activated carbon deodorization units with pocket and synthetic pre-filter, THREE-PHASE V.400/3
 DEODORIZATION UNIT with 23 CYLINDERS of activated vegetable carbon, pocket pre-filter and 2 synthetic filters, max flow rate 7500 m3/cubic/h, revs 1120, V.400/3, Kw.3,00, Weight 330 Kg, dim .mm.2400x1590x800h

€ 4.275,06

VAT excluded
Shipping to be calculated

Delivery from 8 to 15 days**TCF475-004500**

Activated carbon deodorization units with pocket and synthetic pre-filter, THREE-PHASE V.400/3
 DEODORIZATION UNIT with 28 CYLINDERS of activated vegetable carbon, pocket pre-filter and 2 synthetic filters, max flow rate 9000 m3/cubic/h, revs 900, V.400/3, Kw.3,00, Weight 360 Kg, dim .mm.2600x1280x980h

€ 5.023,37

VAT excluded
Shipping to be calculated

Delivery from 8 to 15 days**TCF475-004600**

Activated carbon deodorization units with pocket and synthetic pre-filter, THREE-PHASE V.400/3
 DEODORIZATION UNIT with 36 CYLINDERS of activated vegetable carbon, pocket pre-filter and 2 synthetic filters, max flow rate 12000 m3/cubic/h, rpm 1100, V.400/3, Kw.5,5, Weight 420 Kg, dim .mm.2600x1280x1280h

€ 6.601,59

VAT excluded
Shipping to be calculated

Delivery from 8 to 15 days**TECHNICAL CARD**

CODE/PICTURES

DESCRIPTION

PRICE/DELIVERY

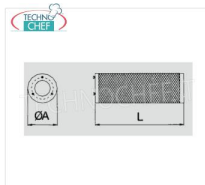
AIF-FCA16

Carbon filter
 Carbon filter, diam.mm.160x400

€ 62,15

VAT excluded
Shipping to be calculated

Delivery from 4 to 9 days**AIF-SCA25**

Coal sack
 Coal bag of 25 Kg

€ 108,02

VAT excluded
Shipping to be calculated

Delivery from 4 to 9 days

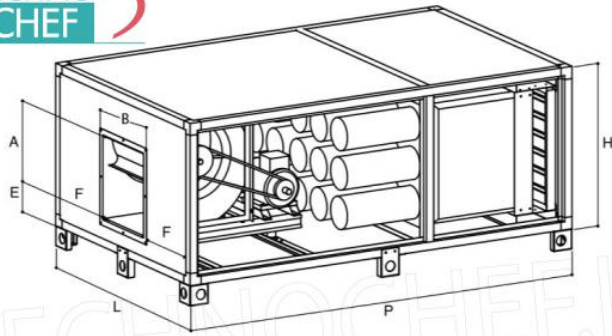

Modello/ Model	N° Cil./ N. Cyl.	m ³ /h	HST H ₂ O	db (A)	kW	rpm	L mm	P mm	H mm	A mm	B mm	E mm	F mm	Kg
CCA 130 A	9	1,1	3000	20	1550	69	670	2000	670	300	342	258	164	155
CCA 130 B	9	1,5	3000	30	1750	72	670	2000	670	300	342	258	164	155
CCA 145 A	14	1,5	4500	20	1280	68	980	2000	750	355	410	297	285	200
CCA 145 B	14	2,2	4500	30	1410	71	980	2000	750	355	410	297	285	200
CCA 160 A	18	2,2	6000	20	1080	72	1280	2100	800	414	384	134	448	290
CCA 160 B	18	2,2	6000	30	1200	73	1280	2100	800	414	384	134	448	290
CCA 175 A*	23	3	7500	20	1000	70	1590	2400	800	414	484	134	553	330
CCA 175 B*	23	3	7500	30	1120	73	1590	2400	800	414	484	134	553	330
CCA 190 A**	28	3	9000	20	800	72	1280	2600	980	492	438	153	421	360
CCA 190 B**	28	3	9000	30	900	76	1280	2600	980	492	438	153	421	360
CCA 1120 A**	36	4	12000	20	890	73	1280	2600	1280	492	570	153	355	420
CCA 1120 B**	36	5,5	12000	30	1100	74	1280	2600	1280	492	570	153	355	420



Ventilatore a trasmissione
Belt driven fan

1

Filtro a carbone attivo
Activated carbon filter

2

Filtro a tasche
Bag filter

3

Filtro piegheettato
Pleated filter

4

